

Spring Hangers

Fig. B-268 Standard Spring Hangers Type: A, B, C, D, E, F, G

Fig. C-268 Corrosion Resistant Spring Hangers Type: A, B, C, D, E, F, G

Design Features:

- Precompression.

Precompressing the spring into the hanger casing provides the following advantages:

1. Saves up to 50% in headroom by reducing the length of the hanger.
2. Reduces the installed height of the overall hanger assembly.
3. Prevents the spring supporting force from exceeding the normal safe limits of variations.
4. Saves valuable erection time because spring is precompressed close to 1/2 of the working range.

Calibration: All ASC Engineered Solutions™ Variable Spring Hangers and supports are calibrated for accurate loading conditions.

- Load indicator is clearly seen in the slot, simplifying reading of the scale plate. Load is read from bottom of indicator.
- Cold set at the factory upon request.
- Spring and casing are fabricated of steel and are rugged and compact.
- Piston cap serves as a centering device or guide maintaining spring alignment.
- Casing protects the spring from damage and weather conditions.

Standard Finish: Painted with semi-gloss primer.

Corrosion Resistant: ASC offers corrosion-resistant and weather-resistant (either galvanized or zinc based primer) Variable Spring Hangers to fill vital needs in the chemical and refinery industries as well as in modern outdoor power plant construction. For protection against severe weather conditions or moderate corrosive conditions, the parts of the hanger are galvanized per ASTM A-153 or painted with zinc based primer, except for the spring which has a protective coating and the load column for Type F which is electro-galvanized.

Advantages of a Protective Coating:

- Protects from a wide range of corrosives.
- Does not affect the flex life of the spring.
- Recommended for ambient temperatures up to 200° F.

Travel Stop: The functional design of the pre-compressed variable spring hanger permits the incorporation of a two-piece travel stop that locks the hanger spring against upward or downward movement for temporary conditions of underload or overload. The complete travel stop, the up travel stop only for cold set purposes or the down travel stop only which may be employed during erection, hydrostatic test (ASC permits a hydrostatic test load of 2 times the normal operating load for the spring hanger) or chemical clean out will be furnished only when specified. The travel stop is painted red and is installed at the factory with a caution tag attached calling attention that the device must be removed before the pipe line is put in service. Permanently attached travel stops available upon request.

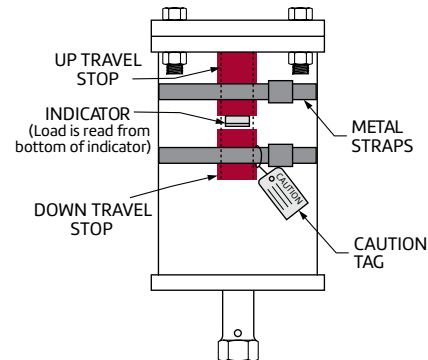

Approvals:

WW-H-171E (Types 51, 56 and 57), ANSI/MSS SP-69 and MSS SP-58 (Types 51, 52 and 53).

Specifications:

ASC Variable Spring Hangers are welded in strict accordance with ASME Section IX.



PROJECT INFORMATION	APPROVAL STAMP
Project:	Approved
Address:	Approved as noted
Contractor:	Not approved
Engineer:	Remarks:
Submittal Date:	
Notes 1:	
Notes 2:	

Fig. B-268 Standard Spring Hangers
Fig. C-268 Corrosion Resistant Spring Hangers

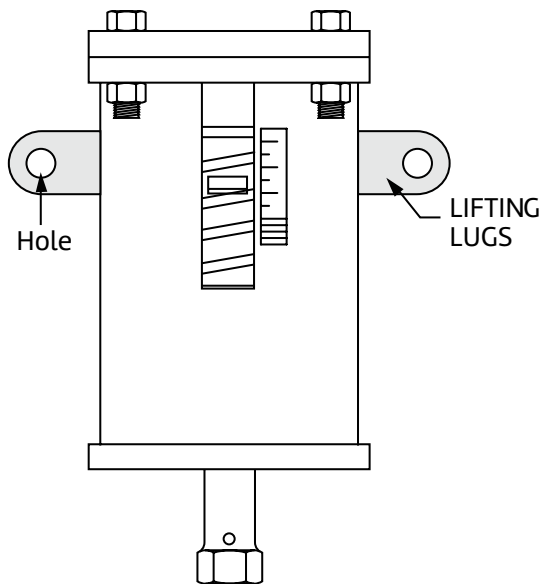

Size Range:

The ASC Engineered Solutions™ Variable Spring Hanger in five series and seven types is offered in twenty-three sizes (Fig. B-268 only is offered in twenty-five sizes). The hanger can be furnished to take loads 10 lbs. to 50,000 lbs.

Ordering:

1. Size
2. Type
3. Figure number
4. Product name
5. Desired supporting force in operating position
6. Calculated amount and direction of pipe movement from installed to operating position.
7. Customer's identification number (if any)
8. When ordering Type F spring specify if roller or guided load column is to be furnished.
9. When ordering Type G, specify total load and load per spring plus center to center rod dimensions.
10. If required, specify with travel stop
11. When ordering corrosion resistant, specify C-268, C-82, C-98, Triple-CR, or Triple-CR, either painted with zinc based primer or completely galvanized, except for coated spring coil.

Note:

To help alleviate the problem of lifting large size spring hangers into position for installation, this product is available with lifting lugs (if required) on sizes weighing one hundred pounds or more.

Fig. B-268 Standard Spring Hangers
Fig. C-268 Corrosion Resistant Spring Hangers

Spring Hangers (Type A)

Type A is the basic unit of Fig. B-268 ASC Variable Spring Hanger. It is designed for attachment to its supporting member by screwing a rod into a tapped hole in the top cap of the hanger the full depth of the top cap ("G" dimension). The upper jam nut should then be locked, securing the hanger. Adjustment of the hanger load is accomplished by turning the coupling on the lower hanger rod until the hanger picks up the load and the load indicator points to the desired position.

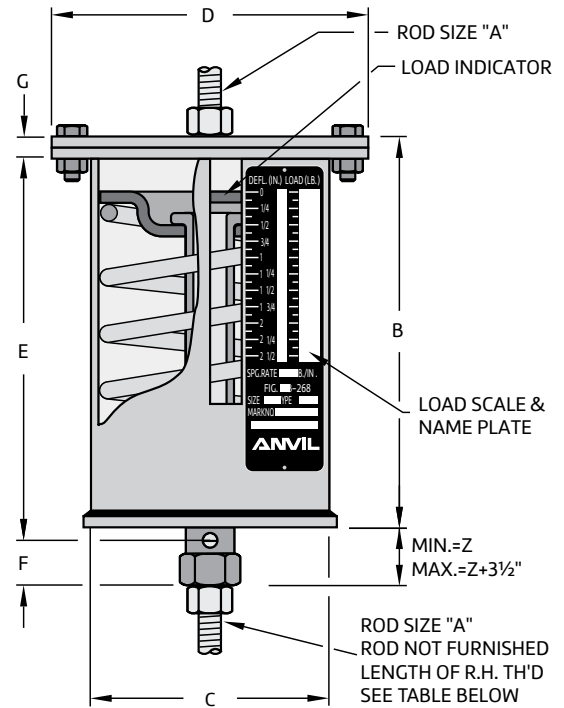

Fig. B-268, Fig. C-268 Type A: Weight (Lbs) • Dimensions (In)

Hanger Size	Weight	Rod Size A	R.H. Thread Length	Casing Length B	Casing Diam. C	Flange Diam. D	Rod Take Out E	Min. Thread Engagement F	Thread Depth G	Z	
000	5	1/2	5	5 5/8	4	5 1/8	5 1/16	1 5/16	7/16	1 3/16	
00	6			7 9/16			7 3/8			1 3/16	
0	8			6 11/16			6 1/16			3/4	
1	8	1/2	5	7 9/16	4	5 1/8	6 15/16	1 5/16	7/16	1	
2	9			8 5/16			7 15/16			1	
3	14			7 15/16			7 9/16			1	
4	15	1/2	5	7 15/16	5 9/16	6 15/16	7 15/16	1 5/16	7/16	1 3/8	
5	16			8 5/8						7 15/16	1 1/16
6	26			8 13/16						7 13/16	9/16
7	29	5/8	5	10	6 5/8	8 3/8	9 1/16	1 5/16	5/8	5/8	
8	31										
9	65	3/4	6	10 7/16	8 5/8	10 3/4	8 15/16	1 1/4	1	3/4	
10	71			12 1/8			11 3/8			1 1/2	
11	65			10 7/16			9 7/8			1 11/16	
12	71	1	6	10 7/16	8 5/8	10 3/4	9 1/2	1 1/4	1	1 1/16	
13	89			13 1/8			11 3/8			1/2	
14	93			13 1/4			11 3/8			3/8	
15	111	1 1/4	7	13 1/4	8 5/8	10 3/4	11 3/8	1 1/4	1 1/4	3/8	
16	133			16 1/16			14 13/16			2 1/16	
17	162	1 3/4	8	18 1/8	8 5/8	11 3/8	16 3/4	1 15/16	1 3/8	1 15/16	
18	330			18 3/4			16			2 9/16	
19	376	2 1/4	9	20 1/2	12 3/4	15 7/8	18 3/8	2 3/4	2 1/4	2 11/16	
20	480			23 3/4			21 5/8				
21	556	2 3/4	10	27 5/16	12 3/4	16 7/8	23 7/8	3 5/8	2 3/4	3 11/16	
22	705			33 3/8			29 3/4			3 3/4	

Fig. B-268 Standard Spring Hangers
Fig. C-268 Corrosion Resistant Spring Hangers

Spring Hangers (Type B & C)

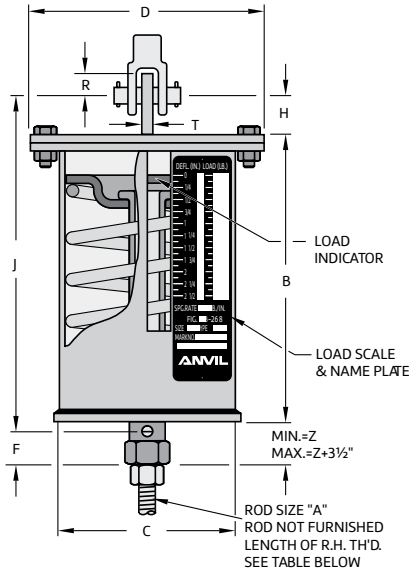

Fig. B-268 Type B

Type B is furnished with a single lug for attachment to the building structure. The lug permits use of a clevis, welded beam attachment or a pair of angles for attachment where headroom is limited.

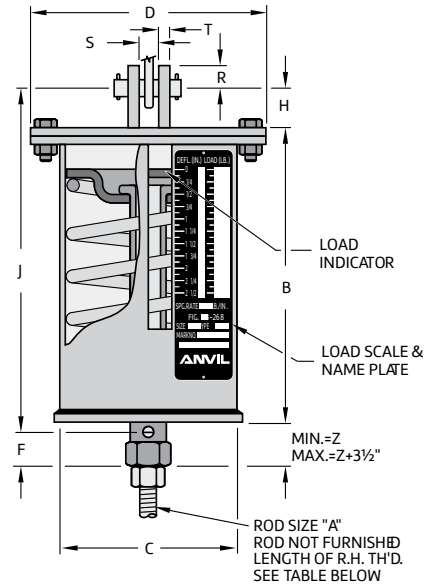

Fig. B-268 Type C

Type C is furnished with two lugs for attachment to the building structure. These two lugs permit the use of an eye rod, Fig. 55L or a single plate for attachment where headroom is limited.

Fig. B-268, Fig. C-268 Type B, C: Weight (Lbs) • Dimensions (In)

Hanger Size	Weight	Rod Size A	R.H. Thread Length	Lug Hole Size	Casing Length B	Casing Diam. C	Flange Diam. D	Min. Thread Engagement F	Height of Pin H	Rod Take Out J	R	Clevis Opening S	Thickness T	Z
000	5	1/2	5	11/16	5 5/8	4	5 1/8	15/16	1 1/2	7	1/4	7/8	1/4	13/16
00	6				7 15/16					9 1/2				1 3/16
0	8				6 11/16					8				
1	9	1/2	5	11/16	7 9/16	4	5 1/8	15/16	1 1/2	8 7/8	1/4	7/8	1/4	3/4
2	10				8 5/16					9 7/8				1
3	14									9 1/2				1
4	16	1/2	5	11/16	7 15/16	5 9/16	6 15/16	15/16	1 1/2	9 7/8	1/4	7/8	1/4	1 3/8
5	17				8 5/8									1 1/16
6	27				8 13/16					9 15/16				9/16
7	30	5/8	5	13/16	10	6 5/8	8 3/8	15/16	1 1/2	11 3/16	1/4	1 1/16	1/4	5/8
8	32													
9	66				10 7/16					11 7/16				3/4
10	72	3/4	6	15/16	12 1/8	8 5/8	10 3/4	1/4	1 1/2	13 7/8	1/4	1 1/4	3/8	1 1/2
11	66				10 7/16					12 3/8				1 11/16
12	71		6		10 7/16					12 1/2				1 1/16
13	89	1		1 1/4	13 1/8	8 5/8	10 3/4	1/4	2	14 3/8	1 1/2	1 5/8	1/2	1/2
14	94	1 1/4	7	1 1/2	13 1/4				3	15 5/8	2	2		3/8
15	114	1 1/4		1 1/2	13 1/4		10 3/4			15 3/8	2	2	5/8	3/8
16	138	1 1/2		1 3/4	16 1/16	8 5/8			3	19 3/16				2 1/16
17	168	1 3/4	8	2	18 1/8		11 3/8	1 15/16		21 1/8	2 1/2	2 5/8	3/4	1 15/16
18	331	2		2 3/8	18 1/4				4	22 1/8				2 9/16
19	378	2 1/4	9	2 5/8	20 1/2	12 3/4	15 7/8	2 3/4		25	3	2 7/8	3/4	
20	486	2 1/2	10	2 7/8	23 3/4				4 1/2	28 3/4	4	3 1/8	1	2 11/16
21	568	2 3/4	10	3 1/8	27 5/16				4 1/2	31 1/8	4	3 5/8		3 11/16
22	714	3	11	3 3/8	33 3/8	12 3/4	16 7/8	3 5/8	5	37 3/4	4	3 7/8	1	3 3/4

Fig. B-268 Standard Spring Hangers
Fig. C-268 Corrosion Resistant Spring Hangers

Spring Hangers (Type D & E)

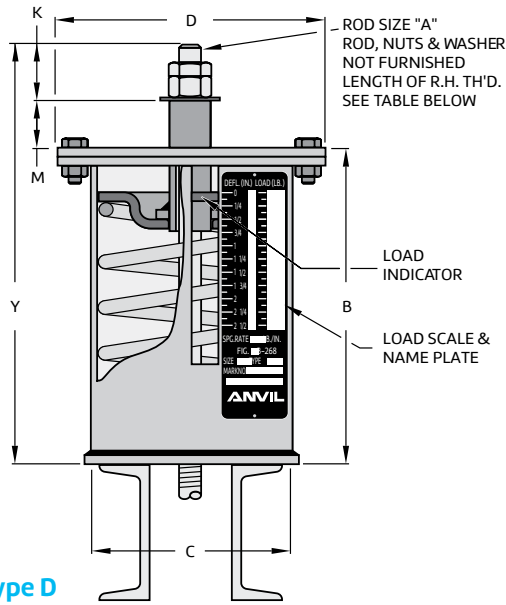

Fig. B-268 Type D

Type D permits adjustment of the hanger from the top. This type has a piece of tubing which passes through a hole in the top cap. Type D is especially adapted for use where the hanger is set above the supporting beams and pipe is suspended below.

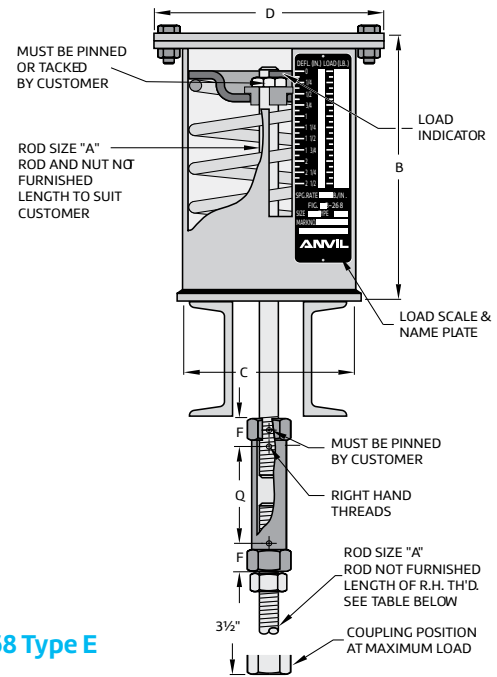

Fig. B-268 Type E

Type E is designed to permit adjustment from either above or below the hanger, when it is installed upon the supporting member and pipe is suspended below. A coupling tapped right hand both ends is furnished.

Fig. B-268, Fig. C-268 Type D, E: Weight (Lbs) • Dimensions (In)

Hanger Size	Weight	Rod Size A	R.H. Thread Length	Casing Length B	Casing Diam. C	Flange Diam. D	Min Thread Engagement F	Allowance for Nuts K	Height of Spacer M	Rod Length Y	Rod Take-out Q
000	5		5	5 ⁵ / ₈	4	5 ¹ / ₈	1 ³ / ₁₆	1 ¹ / ₄	3 ¹ / ₈	10	6
00	6	1/2	5	7 ⁹ / ₁₆	4	5 ¹ / ₈	1 ³ / ₁₆	1 ¹ / ₄	3 ¹ / ₈	11 ³ / ₄	6
0	6		5	6 ¹¹ / ₁₆	4	5 ¹ / ₈	1 ⁵ / ₁₆	1 ¹ / ₄	3 ¹ / ₈	11 ¹ / ₁₆	6
1	7	1/2	5	7 ⁹ / ₁₆	4	5 ¹ / ₈	1 ⁵ / ₁₆	1 ¹ / ₄	3 ¹ / ₈	11 ¹⁵ / ₁₆	6
2	8		5	8 ⁵ / ₁₆						12 ¹¹ / ₁₆	
3	11		5	7 ¹⁵ / ₁₆	5 ⁹ / ₁₆	6 ¹⁵ / ₁₆	1 ⁵ / ₁₆	1 ¹ / ₄	3 ¹ / ₈	11 ¹¹ / ₁₆	6
4	12	1/2	5	8 ⁵ / ₁₆						13	
5	14		5	8 ¹³ / ₁₆						13 ⁵ / ₁₆	
6	22		5	10	6 ⁵ / ₈	8 ³ / ₈	1 ⁵ / ₁₆	1 ¹ / ₂	3	14 ¹ / ₄	6
7	25	5/8	5	10 ⁷ / ₁₆						14 ³ / ₄	
8	26		5	12 ¹ / ₈	8 ⁵ / ₈	10 ³ / ₄	1 ¹ / ₄	1 ³ / ₄	3	15 ⁵ / ₈	6
9	51		6	10 ⁷ / ₁₆						16 ⁷ / ₈	6
10	58	3/4	6	10 ⁷ / ₁₆						14 ¹¹ / ₁₆	
11	51		6	13 ¹ / ₈	8 ⁵ / ₈	10 ³ / ₄	1 ¹ / ₄	2 ¹ / ₄	3	15 ¹³ / ₁₆	6
12	56	1	6	13 ¹ / ₈						18 ⁵ / ₈	6
13	73		7	13 ¹ / ₈						19 ¹ / ₄	
14	77	1 1/4	7	15 ¹⁵ / ₁₆	8 ⁵ / ₈	11 ³ / ₈	1 ¹⁵ / ₁₆	3 ¹ / ₂	3	19 ³ / ₄	6
15	88	1 1/4	7	18						25 ¹ / ₈	
16	107	1 1/2	8	18 ¹ / ₄						25 ¹¹ / ₁₆	
17	133	1 3/4	8	20 ¹ / ₂	12 ³ / ₄	15 ⁷ / ₈	2 ³ / ₄	5	3	28 ³ / ₈	6
18	262	2	9	23 ³ / ₄						32 ³ / ₁₆	
19	300	2 1/4	9	27 ⁷ / ₁₆	12 ³ / ₄	16 ⁷ / ₈	3 ⁵ / ₈	6 ¹ / ₄	3	35 ⁹ / ₁₆	7
20	370	2 1/2	10	33 ³ / ₈						42	
21	455	2 3/4	10								
22	505	3	11								

Fig. B-268 Standard Spring Hangers
Fig. C-268 Corrosion Resistant Spring Hangers

Spring Hangers (Type F)**

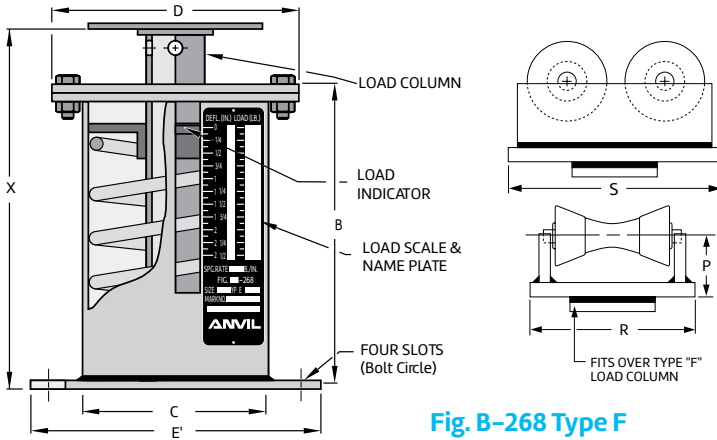

Fig. B-268 Type F

Type F is for use under a base elbow or piping that must be supported directly from the floor. If more than ¼" of horizontal translation occurs of loads resting on the flat load flange or other flat surface junction between the type F spring hanger and the load, a double roller design pipe roll is recommended. Pipe rolls, as illustrated above, will be furnished on request. For dimension of the pipe roll, refer to Fig. 271. Base type variable springs will be furnished

Pipe Roll Dimensions (in) • Load (Lbs)

Roll Size	Roll Mat'l	MaxLoad	P	R	S
2 - 3½	Cast Iron	780	1¾	4½	4½
4 - 6	Cast Iron	1,900	2⅞	5⅞	5½
8 - 10	Cast Iron	4,200	2¾	8¼	6¾
8 - 10	Steel	14,000	2¾	8¼	6¾
12 - 14	Cast Iron	6,150	3½	10⅝	6¾
12 - 14	Steel	26,000	3½	12	6¾
16 - 20	Cast Iron	9,960	3¾	12	6¾
16 - 20	Steel	34,000	3¾	12	6¾
24	Cast Iron	12,200	4	13¼	7
24	Steel	60,000	4	13¼	10
30	Cast Iron	15,000	4½	16½	8¼
30	Steel	60,000	5	16½	10
36	Cast Iron	24,000	4⅝	19	13
36	Steel	60,000	5	19	12

with an extended load column on special order. Guided Load Columns (Type F/G) and roller are available on request.

Adjustment to the required load rating is made by inserting a bar into holes provided in the load column and turning the column. The 2" increment between minimum and maximum "X" dimensions is the amount of field adjustment available and is in excess of the amount required for load adjustment.

Fig. B-268, Fig. C-268 Type F: Weight (Lbs) • Dimensions (In)

Hanger Size	Weight	Casing Length B	Casing Diam. C	Flange Diam. D	Bottom Flange Sq. E	Bottom Flange Bolt Circle		Bottom Flange Bolt	Thickness Bottom Flange	Lengths - X*		Load Col. Diam.	Load Flange Diam.	Thickness of Load Flange
						Min	Max			Min	Max			
000	11	5 ^{11/16}	4	5 ^{1/8}	7 ^{1/2}	7	8 ^{3/4}	3/4	1/4	7 ^{3/16}	9 ^{3/16}	1.9	3 ^{7/8}	3/16
00	12	7 ^{5/8}	4	5 ^{1/8}	7 ^{1/2}	7	8 ^{3/4}	3/4	1/4	9 ^{1/8}	11 ^{1/8}	1.9	3 ^{7/8}	3/16
0	12	6 ^{3/4}	4	5 ^{1/8}	7 ^{1/2}	7	8 ^{3/4}	3/4	1/4	8 ^{1/4}	10 ^{1/4}	1.9	3 ^{7/8}	3/16
1	14	7 ^{5/8}	4	5 ^{1/8}	7 ^{1/2}	7	8 ^{3/4}	3/4	1/4	9 ^{1/8}	11 ^{1/8}	1.9	3 ^{7/8}	3/16
2	15	8 ^{3/8}	4	5 ^{1/8}	7 ^{1/2}	7	8 ^{3/4}	3/4	1/4	9 ^{7/8}	11 ^{7/8}	1.9	3 ^{7/8}	3/16
3	23	8	4	5 ^{1/8}	7 ^{1/2}	7	8 ^{3/4}	3/4	1/4	9 ^{9/16}	11 ^{9/16}	2.875	5 ^{3/8}	3/16
4	25	8 ^{11/16}	4	5 ^{1/8}	7 ^{1/2}	7	8 ^{3/4}	3/4	1/4	10 ^{1/4}	12 ^{1/4}	2.875	5 ^{3/8}	3/16
5	26	8 ^{15/16}	4	5 ^{1/8}	7 ^{1/2}	7	8 ^{3/4}	3/4	1/4	10 ^{1/2}	12 ^{1/2}	2.875	5 ^{3/8}	3/16
6	40	8 ^{15/16}	4	5 ^{1/8}	7 ^{1/2}	7	8 ^{3/4}	3/4	1/4	10 ^{1/2}	12 ^{1/2}	2.875	5 ^{3/8}	3/16
7	46	10 ^{1/8}	6 ^{5/8}	8 ^{3/8}	9	8	10 ^{7/8}	3/4	3/8	11 ^{11/16}	13 ^{11/16}	3.5	6 ^{3/8}	1/4
8	47	10 ^{1/8}	6 ^{5/8}	8 ^{3/8}	9	8	10 ^{7/8}	3/4	3/8	11 ^{11/16}	13 ^{11/16}	3.5	6 ^{3/8}	1/4
9	91	10 ^{9/16}	6 ^{5/8}	8 ^{3/8}	9	8	10 ^{7/8}	3/4	3/8	12 ^{1/8}	14 ^{1/8}	4.5	8 ^{3/8}	1/2
10	98	12 ^{1/4}	8 ^{5/8}	10 ^{3/4}	13 ^{1/4}	10 ^{9/16}	16 ^{1/2}	3/4	1/2	13 ^{13/16}	15 ^{13/16}	4.5	8 ^{3/8}	1/2
11	90	10 ^{9/16}	6 ^{5/8}	8 ^{3/8}	9	8	10 ^{7/8}	3/4	3/8	12 ^{1/8}	14 ^{1/8}	4.5	8 ^{3/8}	1/2
12	95	10 ^{9/16}	6 ^{5/8}	8 ^{3/8}	9	8	10 ^{7/8}	3/4	3/8	12 ^{1/8}	14 ^{1/8}	4.5	8 ^{3/8}	1/2
13	115	13 ^{1/4}	8 ^{5/8}	10 ^{3/4}	13 ^{1/4}	10 ^{9/16}	16 ^{1/2}	3/4	1/2	14 ^{13/16}	16 ^{13/16}	4.5	8 ^{3/8}	1/2
14	119	13 ^{1/4}	8 ^{5/8}	10 ^{3/4}	13 ^{1/4}	10 ^{9/16}	16 ^{1/2}	3/4	1/2	14 ^{13/16}	16 ^{13/16}	4.5	8 ^{3/8}	1/2
15	130	13 ^{1/4}	8 ^{5/8}	10 ^{3/4}	13 ^{1/4}	10 ^{9/16}	16 ^{1/2}	3/4	1/2	14 ^{13/16}	16 ^{13/16}	4.5	8 ^{3/8}	1/2
16	150	15 ^{15/16}	8 ^{5/8}	11 ^{3/8}	13 ^{1/4}	10 ^{9/16}	16 ^{1/2}	3/4	1/2	17 ^{15/16}	19 ^{15/16}	2.0	8 ^{3/8}	1/2
17	173	18	8 ^{5/8}	11 ^{3/8}	13 ^{1/4}	10 ^{9/16}	16 ^{1/2}	3/4	1/2	20	22	2.0	8 ^{3/8}	1/2
18	343	18 ^{1/4}	8 ^{5/8}	11 ^{3/8}	13 ^{1/4}	10 ^{9/16}	16 ^{1/2}	3/4	1/2	20 ^{5/16}	22 ^{5/16}	2.0	8 ^{3/8}	1/2
19	380	20 ^{1/2}	12 ^{3/4}	15 ^{7/8}	17 ^{1/4}	15 ^{3/4}	22	3/4	5/8	22 ^{9/16}	24 ^{9/16}	2.5	12 ^{1/2}	1/2
20	471	23 ^{3/4}	12 ^{3/4}	16 ^{7/8}	17 ^{1/4}	15 ^{3/4}	22	3/4	5/8	25 ^{13/16}	27 ^{13/16}	2.5	12 ^{1/2}	1/2
21	496	27 ^{5/16}	12 ^{3/4}	16 ^{7/8}	17 ^{1/4}	15 ^{3/4}	22	3/4	5/8	29 ^{7/16}	31 ^{7/16}	3.0	12 ^{1/2}	1/2
22	654	33 ^{3/8}	12 ^{3/4}	16 ^{7/8}	17 ^{1/4}	15 ^{3/4}	22	3/4	5/8	35 ^{1/2}	37 ^{1/2}	3.0	12 ^{1/2}	1/2

*Hanger take-out or installed height. With pipe movement up, cold to hot, installed height should be the mid-point between the minimum and maximum "X" dimension, plus thickness of load flange. With pipe movement down, cold to hot installed height should be mid-point between the minimum and maximum "X" dimension, plus the amount of vertical movement and load flange thickness. Note: Sizes 16" and larger are furnished with a hexagon nut at the top of a solid load column to facilitate adjustment with a wrench.

**Springs supplied with a "Guided Load Column" will be ordered as a "Type F/G". Typical all variable spring figure numbers.

Fig. B-268 Standard Spring Hangers Fig. C-268 Corrosion Resistant Spring Hangers

Spring Hangers (Type G)

Type G is a complete trapeze assembly. The hanger consists of two standard spring units plus a pair of back-to-back channels welded at each end to the hanger casing. The "P" dimension can be varied with the customer's instructions. In sizing a Type G hanger, it must be remembered that each standard spring unit carries one-half of the total pipe load. Therefore, in using the hanger selection chart, use one-half of the total pipe load as the hot load. When the pipe line is designed so as not to be centered on the channel, one spring of the trapeze will carry a heavier load, the other a lighter load. Care should be taken in calculating the load of each hanger and in choosing the proper sized spring in such cases. The center-to-center rod dimension must be specified when ordering.

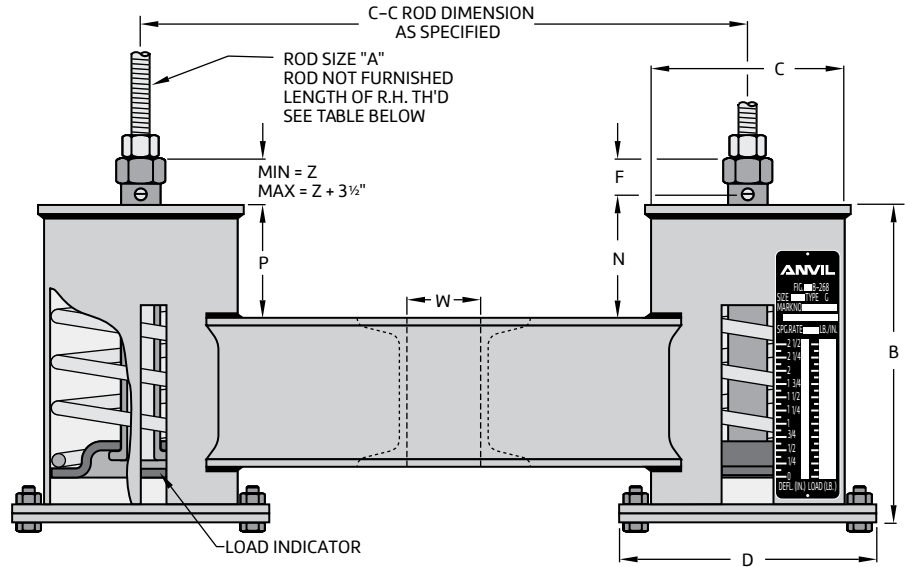

Fig. B-268 Type G

Fig. B-268, Fig. C-268 Type G: Weight (Lbs) • Dimensions (In)

Hanger Size	Weight*	Rod Size A	R.H. Thread Length	Casing Length B	Casing Diam. C	Flange Diam. D	Min. Thread Engagement F	Rod Take Out N	Channel Size (lb/ft)	Max C-C	Space Between Channels W	P	Z
000	24			5 ³ / ₈				1 ³ / ₈					1 ³ / ₁₆
00	26	1/2	5	7 ⁹ / ₁₆	4	5 ¹ / ₈	1 ⁵ / ₁₆	1 ³ / ₄	C3 x 4.1	24	5/8	1 1/2	1 ³ / ₁₆
0	30			6 ¹¹ / ₁₆				1 ⁵ / ₁₆					3/4
1	31	1/2	5	7 ⁹ / ₁₆	4	5 ¹ / ₈	1 ⁵ / ₁₆	1 ⁵ / ₁₆	C3 x 4.1	24	5/8	1 1/2	1
2	32			8 ⁵ / ₁₆				1 ⁹ / ₁₆					1
3	41			7 ¹⁵ / ₁₆				2 ¹ / ₁₆					1
4	42	1/2	5	8 ⁵ / ₁₆	5 ⁹ / ₁₆	6 ¹⁵ / ₁₆	1 ⁵ / ₁₆	2 ⁷ / ₁₆	C3 x 4.1	30	3/4	2	1 ³ / ₈
5	43			8 ⁵ / ₁₆				1 ³ / ₄					1 ¹ / ₁₆
6	63			8 ¹³ / ₁₆				1 ⁵ / ₈					9/16
7	69	5/8	5	10	6 ⁵ / ₈	8 ³ / ₈	1 ⁵ / ₁₆	1 ¹¹ / ₁₆	C3 x 4.1	36	1	2	5/8
8	73			10 ⁷ / ₁₆				2 ¹ / ₂					3/4
10	157	3/4	6	12 ¹ / ₈	8 ⁵ / ₈	10 ³ / ₄	1 ¹ / ₄	3 ³ / ₄	C4 x 5.4	36	1 ¹ / ₄	3	1 ¹ / ₂
11	145			10 ⁷ / ₁₆				3 ⁷ / ₁₆					1 ¹¹ / ₁₆
12	157	1	6	10 ⁷ / ₁₆				3 ¹³ / ₁₆					1 ¹ / ₁₆
13	195		7	13 ¹ / ₈	8 ⁵ / ₈	10 ³ / ₄	1 ¹ / ₄	3 ³ / ₄	C5 x 6.7	36	1 ¹ / ₂	3	1 ¹ / ₂
14	203	1 ¹ / ₄	7	13 ¹ / ₄				3 ¹ / ₈		33			3/8
15	250	1 ¹ / ₄	7	13 ¹ / ₄		10 ³ / ₄		3 ¹⁵ / ₁₆	C6 x 10.5		1 ¹ / ₂		3/8
16	298	1 ¹ / ₂	8	16 ¹ / ₁₆	8 ⁵ / ₈	11 ³ / ₈	1 ¹⁵ / ₁₆	4 ¹ / ₈	C8 x 11.5	36	2 ¹ / ₈	3	2 ¹ / ₁₆
17	354	1 ³ / ₄	8	18 ¹ / ₈				4					1 ¹⁵ / ₁₆
18	690	2	9	18 ¹ / ₄				4			2 ³ / ₈		2 ⁹ / ₁₆
19	783	2 ¹ / ₄	10	20 ¹ / ₂	12 ³ / ₄	15 ⁷ / ₈	2 ³ / ₄	4 ¹ / ₈	C12 x 20.7	42	2 ⁵ / ₈	3	2 ¹¹ / ₁₆
20	993	2 ¹ / ₂	10	23 ³ / ₄				4 ¹ / ₈		40	2 ⁷ / ₈		2 ¹¹ / ₁₆
21	1,197	2 ³ / ₄	10	27 ⁵ / ₁₆	12 ³ / ₄	16 ⁷ / ₈	3 ⁵ / ₈	4 ⁵ / ₁₆	C15 x 33.9	48	3 ¹ / ₈	3	3 ¹¹ / ₁₆
22	1,496	3	11	33 ³ / ₈				4 ³ / ₈			3 ³ / ₈		3 ³ / ₄

*Weight based on 24" center-to-center dimension.

Fig. B-268 Standard Spring Hangers
Fig. C-268 Corrosion Resistant Spring Hangers

How to Determine Type: The type of variable spring hanger to be used depends upon the physical characteristics required by the suspension problem (e.g., amount of head room, whether pipe is to be supported above or below the spring, etc.).

Consideration should be given to the seven standard types offered (see illustration below). Special variable spring hangers can be fabricated for unusual conditions.

Spring Hanger Types – Typical Applications

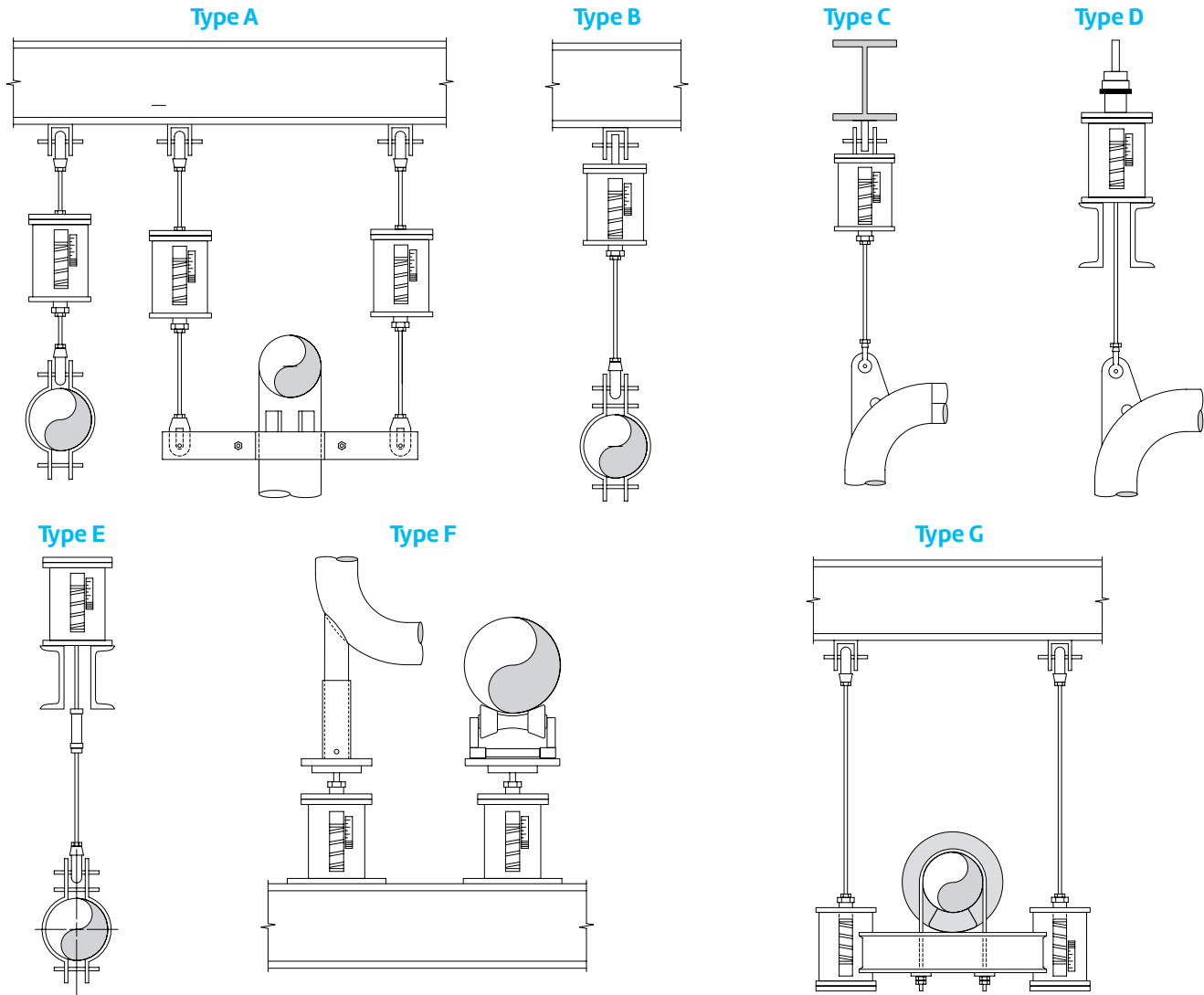

Recommended Service: Pipe hangers located at points that are subject to vertical thermal movement and for which a constant support hanger is not required (see "recommended service" for constant supports in the pipe hanger catalog). Type D & E spring hangers may accommodate less than 4° of rod swing depending on size, figure number, and application.

Installation: Securely attach hanger to the building. Attach lower hanger rod and turn the load coupling until the load indicator is positioned at the desired setting indicated on the load scale plate.

Adjustment of Hanger: Once installed in the line; the hanger should be adjusted until the load indicator moves to the white button marked "C" (cold position). On inspection of the system, after a reasonable period of operation, the load indicator should be at the red button marked "H" (hot position). If it is not, the hanger should be readjusted to the hot position. No other adjustment is necessary.

How to Determine Series: Complete sizing information is given in the hanger selection chart on the following pages. The sizing information is applicable to hangers of all series. As noted on the hanger selection charts that the total spring deflection in the casing leaves a reserve (overtravel) above and below the recommended working load range.

Spring Hanger Size and Series Selection

How to Use Hanger Selection Table:

In order to choose a proper size hanger, it is necessary to know the actual load which the spring is to support and the amount and direction of the pipe line movement from the cold to the hot position.

Find the actual load of the pipe in the load table. As it is desirable to support the actual weight of the pipe when the line is hot, the actual load is the hot load. To determine the cold load, read the spring scale, up or down, for the amount of expected movement.

The chart must be read opposite from the direction of the pipe's movement. The load arrived at is the cold load. If the cold load falls outside of the working load range of the hanger selected, relocate the actual or hot load in the adjacent column and find the cold load. When the hot and cold loads are both within the working range of a hanger, the size number of that hanger will be found at the top of the column.

Load Table (Lbs) For Selection of Hanger Size (sizes 10 through 22 on next page)

Working Range (in) unshaded Shaded Rows Show Overtravel					Hanger Size												
Figure No.					B-268 Only			Fig. 82, Fig. B-268, Fig. 98, Triple & Quadruple Spring									
Quad.	Triple	98	B-268	82	000	00	0	1	2	3	4	5	6	7	8	9	
2	1½	1	½	¼	7	19	43	63	81	105	141	189	252	336	450	600	
					7	20	44	66	84	109	147	197	263	350	469	625	
					8	22	46	68	88	114	153	206	273	364	488	650	
					9	24	48	71	91	118	159	213	284	378	506	675	
0	0	0	0	0	10	26	50	74	95	123	165	221	294	392	525	700	
					11	28	52	76	98	127	170	228	305	406	544	725	
					12	30	54	79	101	131	176	236	315	420	563	750	
					12	31	56	81	105	136	182	244	326	434	581	775	
2	1½	1	½	¼	14	34	58	84	108	140	188	252	336	448	600	800	
					14	35	59	87	111	144	194	260	347	462	619	825	
					15	38	61	89	115	149	200	268	357	476	638	850	
					16	40	63	92	118	153	206	276	368	490	656	875	
4	3	2	1	½	17	41	65	95	122	158	212	284	378	504	675	900	
					18	43	67	97	125	162	217	291	389	518	694	925	
					19	45	69	100	128	166	223	299	399	532	713	950	
					20	47	71	102	132	171	229	307	410	546	731	975	
6	4½	3	1½	¾	21	49	73	105	135	175	235	315	420	560	750	1,000	
					21	50	74	108	138	179	241	323	431	574	769	1,025	
					22	53	76	110	142	184	247	331	441	588	788	1,050	
					23	55	78	113	145	188	253	339	452	602	806	1,075	
8	6	4	2	1	24	56	80	116	149	193	258	347	462	616	825	1,100	
					25	58	82	118	152	197	264	354	473	630	844	1,125	
					26	60	84	121	155	201	270	362	483	644	863	1,150	
					27	62	86	123	159	206	276	370	494	658	881	1,175	
10	7½	5	2½	1¼	28	64	88	126	162	210	282	378	504	672	900	1,200	
2	1½	1	½	¼	28	66	89	129	165	214	288	386	515	686	919	1,225	
					29	68	91	131	169	219	294	394	525	700	938	1,250	
					30	70	93	134	172	223	300	402	536	714	956	1,275	
					31	72	95	137	176	228	306	410	546	728	975	1,300	
					Spring Rate (lbs/in)												
					82	-	-	30	42	54	70	94	126	168	224	300	400
					B-268	7	15	15	21	27	35	47	63	84	112	150	200
					98	-	-	7	10	13	17	23	31	42	56	75	100
					Triple	-	-	5	7	9	12	16	21	28	37	50	67
					Quadruple	-	-	4	5	7	9	12	16	21	28	38	50

Note: General rule for series selection use Fig. 82 for up to ½" of movement up to 1" use Fig. B-268, up to 2" use Fig. 98, up to 3" use a Triple, up to 4" use a Quadruple. Double check to assure desired variability is achieved.

Spring Hanger Size and Series Selection

How to Use Hanger Selection Table (cont.): Should it be impossible to select a hanger in a particular series such that both loads occur within the working range, consideration should be given to a variable spring hanger with a wider working range or a constant support hanger. The cold load is calculated by adding (for up movement) or subtracting (for down movement) the product of spring rate times movement to or from the hot load.

$$\text{Cold load} = (\text{hot load}) \pm (\text{movement}) \times (\text{spring rate})$$

A key criteria in selecting the size and series of a variable spring is a factor known as variability. This is a measurement of the percentage change in supporting force between the hot and cold positions of a spring and is calculated from the formula:

$$\text{Variability} = (\text{Movement}) \times (\text{Spring Rate}) / (\text{Hot Load})$$

If an allowable variability is not specified, good practice would be to use 25% as recommended by MSS-SP-58.

Load Table (Lbs) For Selection of Hanger Size (Continued from previous page)

Hanger Size												Working Range (in) unshaded Shaded Rows Show Overtravel					
Fig. 82, Fig. B-268, Fig. 98, Triple & Quadruple Spring												Figure No.					
10	11	12	13	14	15	16	17	18	19	20	21	22	82	B-268	98	Triple	Quad.
780	1,020	1,350	1,800	2,400	3,240	4,500	6,000	7,990	10,610	14,100	18,750	25,005					
813	1,063	1,406	1,875	2,500	3,375	4,688	6,250	8,322	11,053	14,588	19,531	26,047	¼	½	1	1½	2
845	1,105	1,463	1,950	2,600	3,510	4,875	6,500	8,655	11,495	15,275	20,313	27,089					
878	1,148	1,519	2,025	2,700	3,645	5,063	6,750	8,987	11,938	15,863	21,094	28,131					
910	1,190	1,575	2,100	2,800	3,780	5,250	7,000	9,320	12,380	16,450	21,875	29,173					
943	1,233	1,631	2,175	2,900	3,915	5,438	7,250	9,652	12,823	17,038	22,656	30,215	0	0	0	0	0
975	1,275	1,688	2,250	3,000	4,050	5,625	7,500	9,985	13,265	17,625	23,438	31,256					
1,008	1,318	1,744	2,325	3,100	4,185	5,813	7,750	10,317	13,708	18,213	24,219	32,298					
1,040	1,360	1,800	2,400	3,200	4,320	6,000	8,000	10,650	14,150	18,800	25,000	33,340					
1,073	1,403	1,856	2,475	3,300	4,455	6,188	8,250	10,982	14,592	19,388	25,781	34,382	¼	½	1	1½	2
1,105	1,445	1,913	2,550	3,400	4,590	6,375	8,500	11,315	15,035	19,975	26,563	35,424					
1,138	1,488	1,969	2,625	3,500	4,725	6,563	8,750	11,647	15,477	20,563	27,344	36,466					
1,170	1,530	2,025	2,700	3,600	4,860	6,750	9,000	11,980	15,920	21,150	28,125	37,508					
1,203	1,573	2,081	2,775	3,700	4,995	6,938	9,250	12,312	16,362	21,738	28,906	38,549	½	1	2	3	4
1,235	1,615	2,138	2,850	3,800	5,130	7,125	9,500	12,645	16,805	22,325	29,688	39,591					
1,268	1,658	2,194	2,925	3,900	5,265	7,313	9,750	12,977	17,247	22,913	30,469	40,633					
1,300	1,700	2,250	3,000	4,000	5,400	7,500	10,000	13,310	17,690	23,500	31,250	41,675					
1,333	1,743	2,306	3,075	4,100	5,535	7,688	10,250	13,642	18,132	24,088	32,031	42,717	¾	1½	3	4½	6
1,365	1,785	2,363	3,150	4,200	5,670	7,875	10,500	13,975	18,575	24,675	32,813	43,759					
1,398	1,828	2,419	3,225	4,300	5,805	8,063	10,750	14,307	19,017	25,263	33,594	44,801					
1,430	1,870	2,475	3,300	4,400	5,940	8,250	11,000	14,640	19,460	25,850	34,375	45,843					
1,463	1,913	2,531	3,375	4,500	6,075	8,438	11,250	14,972	19,902	26,438	35,156	46,885	1	2	4	6	8
1,495	1,955	2,588	3,450	4,600	6,210	8,625	11,500	15,305	20,345	27,025	35,938	47,926					
1,528	1,998	2,644	3,525	4,700	6,345	8,813	11,750	15,637	20,787	27,613	36,719	48,968					
1,560	2,040	2,700	3,600	4,800	6,480	9,000	12,000	15,970	21,230	28,200	37,500	50,010	¼	2½	5	7½	10
1,593	2,083	2,756	3,675	4,900	6,615	9,188	12,250	16,302	21,672	28,788	38,281	51,052					
1,625	2,125	2,813	3,750	5,000	6,750	9,375	12,500	16,635	22,115	29,375	39,063	52,094	¼	½	1	1½	2
1,658	2,168	2,869	3,825	5,100	6,885	9,563	12,750	16,967	22,557	29,963	39,844	53,136					
1,690	2,210	2,925	3,900	5,200	7,020	9,750	13,000	17,300	23,000	30,550	40,625	54,178					
Spring Rate (lbs/in)																	
520	680	900	1,200	1,600	2,160	3,000	4,000	5,320	7,080	9,400	12,500	16,670	82				
260	340	450	600	800	1,080	1,500	2,000	2,660	3,540	4,700	6,250	8,335	B268				
130	170	225	300	400	540	750	1,000	1,330	1,770	2,350	3,125	4,167	98				
87	113	150	200	267	360	500	667	887	1,180	1,567	2,083	2,778	Triple				
65	85	113	150	200	270	375	500	665	885	1,175	1,563	2,084	Quadruple				

Note: General rule for series selection use Fig. 82 for up to ½" of movement up to 1" use Fig. B-268, up to 2" use Fig. 98, up to 3" use a Triple, up to 4" use a Quadruple. Double check to assure desired variability is achieved.